

**GUIDELINE ON
FORMATTING, ASSEMBLING,
AND SUBMITTING NEW DRUG
AND ANTIBIOTIC APPLICATIONS**

US DEPARTMENT OF HEALTH AND HUMAN SERVICES
PUBLIC HEALTH SERVICE
FOOD AND DRUG ADMINISTRATION

ERRATA

Page 7, Second Paragraph

Line 9: Change "Forms and Publications Distribution
(HFA-268)
12100 Parklawn Drive
Rockville, Maryland 20852"

to

"Consolidated, Forms and Publications Distribution
Washington Commerce Center
3222 Hubbard Road
Landover, Maryland 20785"

Center for Drugs and Biologics
Food and Drug Administration
Department of Health and Human Services

**GUIDELINE ON FORMATTING, ASSEMBLING,
AND SUMMING NEW DRUG AND ANTIBIOTIC APPLICATIONS**

February 1987

For further information regarding the guideline please contacts

Food and Drug Administration
Center for Drugs and Biologics
Product Information Coordination Staff (HM-46)
5600 Fishers Lane
Rockville, MD 20857
(301-443-4320)

TABLE OF CONTENTS

I. INTRODUCTION	6
II. APPLICATION FORMAT	7
A. Number of Copies	7
1. Archival Copy	7
2. Review Copy.....	7
B. Assembling the Application	9
1. Jackets	9
2. Paper Size and Binding	10
3. Volume Size and Identification.....	11
4. Pagination	12
5. Packing carton.....	12
6. Supplements, Amendments, and Postmarketing Reports.....	13
III. APPLICATION CONTENT.....	13
A. Full Application	13
1. Archival Copy.....	13
2. Review Copy.....	17
3. Pre-submission of Chemistry, Manufacturing, ante Controls Section	17
B. Abbreviated Applications (ANDAs).....	18
IV. OTHER AVAILABLE GUIDELINES.....	18
Appendix A.....	19
Appendix B-1	21
Appendix B-2.....	23

GUIDELINE ON FORMATTING, ASSEMBLING, AND SUBMITTING NEW DRUG AND ANTIBIOTIC APPLICATIONS

I. INTRODUCTION

The Federal Food, Drug, and Cosmetic Act (the act) provides that a new drug may not be introduced or delivered for introduction into interstate commerce unless the Food and Drug Administration (FDA) has approved a new drug application (NDA) for it (21 U.S.C. 355). FDA approves an application for a new drug only if the applicant demonstrates by adequate scientific evidence that the drug is safe and by substantial evidence that the drug is effective for the conditions prescribed, recommended, or suggested in proposed labeling for the product. The act defines substantial evidence of effectiveness as "evidence consisting of adequate and well-controlled investigations, including clinical investigations" that are conducted by qualified experts. Additionally, to obtain approval, an applicant is required to show that the methods used in, and the facilities and controls used for, the manufacturing, processing, and packaging of the drug are adequate to preserve its identity, strength, quality, and purity.

To obtain the evidence needed to show whether a drug is safe and effective, the applicant generally must perform studies of the drug in animals (preclinical studies) and in humans (clinical studies).

The purpose of preclinical testing is two-fold. First, it is conducted as an aid in assessing whether initial human studies will be acceptably safe. Second, such studies are conducted to predict the therapeutic activity of the drug. If the drug looks promising, human clinical studies are proposed in an Investigational New Drug Application (IND).

The IND must contain sufficient information about the investigational drug to show it is reasonably safe to begin human testing. An IND for a drug not previously tested in human subjects will ordinarily include, in addition to other information, the results of preclinical studies, the protocols for the planned human tests, and information on the composition, source, and method of manufacture of the drug.

Drug testing in humans proceeds progressively through three phases (called Phases 1, 2, and 3). Phase 1 includes the initial introduction of an investigational drug into humans and consists of short-term studies in a small number of healthy subjects, or patients with the target disease, to determine the metabolism and basic pharmacologic and toxicological properties of the drug, and if possible, to obtain preliminary evidence of effectiveness. Phase 2 consists of larger, more detailed studies, usually including the first controlled clinical studies intended to assess the effectiveness of the drug and to determine the common short-term side effects and risks of the drug. Phase 3 studies are expanded controlled and uncontrolled trials. They are performed after preliminary evidence of effectiveness has been established and are designed to gather the additional information about effectiveness and safety that is needed to evaluate the overall benefit-risk relationship of the drug and to provide an adequate basis for professional labeling. Regulations governing the conduct of investigational new drug studies are set forth under 21 CFR Part 312. Additionally, regulations on the protection of human subjects in clinical investigations regarding informed consent and institutional review board (IRB) review and approval are set forth in 21 CFR Part 50 and 21 CFR Part 56, respectively. The agency also has developed a series of clinical guidelines that describe how applicants may conduct studies on particular classes of drugs so that the studies are likely to yield data that can be used to determine whether a drug is safe and effective.

The act requires that anyone who seeks to market a new drug submit the results of investigational studies to FDA in an NDA and obtain FDA's approval. Section 505(b) of the act requires that an application contain: (1) full reports of studies (both preclinical and clinical) to demonstrate the safety and effectiveness of the drug, (2) a description of the components, chemical formulation, and manufacturing controls, and (3) samples of the drug itself and of the proposed labeling. The act requires FDA either to approve the application or to issue a notice of an opportunity for a hearing on whether the application is approvable within 180 days of its filing, unless the applicant and FDA agree to an extended time period. Regulations implementing the statutory requirements for obtaining marketing approval for new drugs and antibiotics are set forth under 21 CFR Part 314. In the FEDERAL REGISTER of February 22, 1985 (50 FR 7452), FDA published a final rule revising those regulations as part of a broader agency plan to improve the new drug approval process. This guideline applies to the revised regulations.

This guideline is issued under 21 CFR 10.90. An applicant may, but is not required to, rely upon the guideline in formatting, assembling and submitting an application to market a new drug or antibiotic. When a different approach is chosen, applicants are encouraged to discuss the matter in advance with FDA to prevent the expenditure of money and effort on preparing a submission that may later be determined to be unacceptable.

II. APPLICATION FORMAT

A. Number of Copies

Section 314.50 of the regulations requires the submission of two copies of each application, an archival copy and a review copy. A breakdown of the contents of the application appears in Appendix A.

1. Archival Copy

The archival copy is a complete copy of an application submission and, during the review of the application, is intended to serve as a reference source for agency reviewers to find information not contained in the review copy, as a reference source for other agency officials, and as the repository of the copies of tabulations and case resort forms on the clinical studies. After an application is approved, the archival copy is retained by the agency and serves as the sole file copy of the approved application. FLEA will accept certain parts of the archival copy of an application on microfiche or another suitable microform system. (See "Guideline for the Submission in Microfiche of the Archival Copy of an Application.") More detailed information about the contents of the archival copy is included in section III of this guideline.

2. Review Copy

The review copy of an application is divided into five technical sections (six, if a microbiology section is required) that contain the scientific information needed for FDA review of the application. The submission of the review copy in sections permits concurrent review of the application by FDA reviewing disciplines: clinical, pharmacology, chemistry, statistics, biopharmaceutics, and microbiology.

The review sections should be separately bound (see Attachment A). Each review section should contain a copy of the application form (gym FM 356h), a copy of the cover letter, a copy of the summary, a copy of the index to the entire application, an index for the specific review section, and letters of reference or authorization, if appropriate. More detailed information about the review copy is included in section III of this guideline.

B. Assembling the Application

1. Jackets

To facilitate filing and distribution of submissions within the agency, FDA suggests that the archival copy and each review copy be bound in color-coded jackets as follows:

	<u>Jacket Color</u>	<u>Form Number</u>
<u>Archival Copy</u>	Blue	FDA 2626
<u>Review Copy</u>		
Chemistry, Manufacturing and Controls Section	Red	FDA 2626a
Nonclinical Pharmacology and Toxicology Section	Yellow	FDA 2626b
Human Pharmacokinetics and Bioavailability Section	Orange	FDA 2626c
Microbiology Section	White	FLEA 2626d
Clinical Data Section	Light-Brown	FDA 2626e
Statistical Section	Green	FDA 2626f

The cover of each jacket should bear the name of the applicant, the name of the drug product, and the appropriate heading identifying the submission, that is, "Archival Copy," "Chemistry", "Pharmacology," "Pharmacokinetics," "Microbiology," "Clinical," or "Statistical."

Applicants may request supplies of the jackets free of charge from FDA. Requests should be written and should specify the color of the jacket, the FDA form number, the quantity required, the name of the company and the address to which the shipment is to be sent, and the name and telephone number of a contact person in case additional information regarding the order is needed. Requests for orders of jackets should be sent to:

Forms and Publications Distribution (HFA-268)
12100 Parklawn Drive
Rockville, Maryland 20852

Because FLEA budgets occasionally limit the number of jackets that are available from the agency warehouse, firms are asked to limit requests to the minimum number of jackets needed for their submissions. Orders exceeding a reasonable amount will require special consideration.

If jackets are out of stock, the requester will be notified in writing of the approximate time a new supply is expected. The original request will be retained and the order filled when the item is again available.

A company may also obtain the colored jackets needed for its submission from commercial sources. It is recommended that commercially obtainable jackets conform to the following specifications:

Archival Copy - polyvinyl type jacket .023 to .025 gauge poly, high-density (linear) polyethylene

(Front cover) - 9" x 11 1/2"

(Back cover) - 9" x 12" with full 1/2" tab along top edge.

Review Copy - Extra-heavy paper jacket

(Front cover) - 9" x 11 1/2"

(Back cover) - 9" x 12" with full 1/2" tab along top edge

Both types of jackets have a hidden reinforced 1" hinge on the front and back cover with slots punched 8 1/2" centered. The two outside corners of both the front and back covers should be rounded.

2. Paper Size and Binding

FDA's system for filing applications requires that an application be bound on the left side of a page using the U.S. standard-size loose-leaf gage size (8 1/2" x 11"). Page size is illustrated in Figure 1 below:

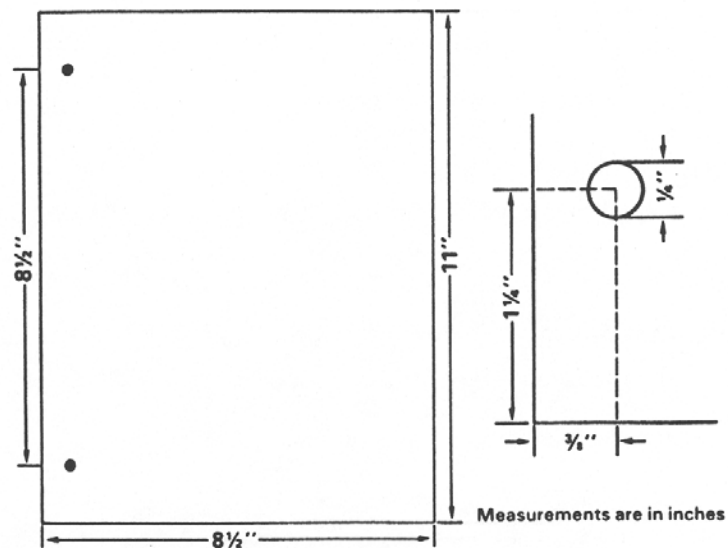

Figure 1
Standard Page Dimensions for FDA Jackets

All pages should be paginated and half punched 8 1/2" centered. The left margin should be at least 3/8" from the edge to avoid obscuring information or data. Volumes should be bound with fasteners rather than three-ring binders.

Both sides of a page may be used for the presentation of information and data provided that:

- Adequate margin space is maintained so that information and data are not obscured in the binding to cause problems in reviewing or photocopying the pages.
- Legibility is not impaired because of bleeding of the copy through the page.
- Pages are in correct order and are accurately numbered.

3. Volume Size and Identification

Volumes submitted in hard copy form should be no more than 2 inches thick.

The front cover of each volume should display the name of the applicant, the name of the drug, and the application number, if preassigned. Applicants submitting applications greater than 50 volumes may obtain a preassigned number by contacting the Central Document Room (301-443-0035).

Preprinted on the lower right-hand corner of each FDA-supplied jacket is "____ of ____ volumes." This phrase should be completed by the applicant for the original submission and every subsequent submission to identify the specific volume and the total number of volumes submitted in the archival copy. For example, the first volume of a 50-volume submission would read "1 of 50 volumes." Numbering of the review sections should be the same as that used for the volumes of the archival copy.

Preprinted on the upper right-hand corner of each FDA-supplied jacket is "Volume." Applicants should fill in this blank only for original applications and for chemistry pre-submissions; FDA will complete for submissions made after the original application. The blank should be filled in with two numbers, the first giving the order in which the submission has been made and the second identifying the specific volume of the total number in that submission. For example, if the original application is the first submission and contains 50 volumes, the volumes should be numbered from 1.1 to 1.50. If the 50-volume original application is submitted after a 3-volume pre-submission has been made, the pre-submission volumes would be numbered from 1.1 to 1.3 and the original application would then be numbered from 2.1 to 2.50.

Jackets supplied by the drug firm should be numbered in the same way as preprinted jackets provided by FDA.

When the archival copy of the application is submitted in microfiche, NDA numbers are preassigned. Microfiche corresponding to more than one volume of the paper (hard copy) application may be bound together provided a clear physical separation is made between each "volume" of microfiche. This separation might be indicated by leaving one or more

empty slots between the last microfiche sheet of one volume and the first microfiche sheet of the next. For more information, refer to the FDA "Guideline for the Submission in Microfiche of the Archival Copy of an Application."

4. Pagination

Applicants may adopt any method for paginating as long as the paging and indexing permit rapid access to the entire submission. Whatever pagination method is adopted, it is important that all pages in the application be numbered and that the numbering of the review copy pages be the same as the numbering of the corresponding pages in the archival copy.

If the archival copy is submitted in microfiche, the page numbers on the microfiche page image should correspond to the page numbers in the review copy.

5. Packing carton

FDA recommends shipping applications in boxes measuring 14" x 12" x 9 1/2". Use of this standard box size greatly facilitates storage. Because abbreviated applications (ANDAs) are handled and stored separately, smaller boxes may be appropriate for them.

The exterior of the packing carton should identify the contents by drug name, applicant's name, and volume numbers: The packing carton should also identify which cartons contain the archival copy and which contain the review copy.

Full application submissions should be sent to:

Food and Drug Administration
Center for Drugs and Biologics
Central Document Room
Park Building, Room 214
12420 Parklawn Drive
Rockville, Maryland 20852

Abbreviated application submissions should be sent to:

Food and Drug Administration
Center for Drugs and Biologics
Division of Generic Drugs (HFN-2300)
Document Control Room 17B20
5600 Fishers Lane
Rockville, Maryland 20857

Abbreviated antibiotic application submissions should be sent to: Food and Drug Administration Center for Drugs and Biologics Division of Generic Drugs (HILT-235) Document Control Room 17-48 5600 Fishers Lane Rockville, Maryland 20857

6. Supplements, Amendments, and Postmarketing Reports

The submission format for an amendment to a pending application or supplement to an approved application should be the same as that used for an original application. Each submission should consist of two copies, a complete archival copy and an appropriately sized review copy. Volumes and page numbers should be identified as described in Section II of this guideline. Amendments, supplements, resubmissions, annual reports, and other correspondence concerning a full application should be sent to the appropriate FLT reviewing division (see Appendix B for addresses).

Postmarketing reports of adverse drug experiences for NDAs and ANDAs including the 15-day "Alert Reports" and the "Periodic Drug Experience Reports" should be submitted in duplicate to:

Food and Drug Administration
Center for Drugs and Biologics
Central Document Room Park Building, Room 214
12420 Parklawn Drive
Rockville, Maryland 20852

The Periodic Drug Experience Reports should be bound in double-pronged (8 1/2" center-hole-punched) jackets. Additional information regarding the submission of drug experience reports may be obtained from the FDA, "Guideline on Postmarketing Reporting of Adverse Drug Reactions."

III. APPLICATION CONTENT

A. Full Application

1. Archival Copy

The archival copy of an application should include a cover letter to: (i) confirm any agreements or understandings between FM and the applicant; (ii) identify one or more persons the agency may contact regarding the application; and (iii) convey any other important information about the application. The archival copy of an application should contain the following data and information in the order listed below:

- a. Application Form (§ 314.50(a)) (Form FDA 356h). This form serves as a cover sheet for the application. It contains basic identifying information about the applicant and the drug product that is the subject of the application and obligates the applicant to comply with applicable laws and regulations. The application form should be signed by the applicant, or the applicant's attorney, agent, or other authorized official. If the person signing the application does not reside or have a place of business within the United States, the application must contain the name and address of, and be countersigned by, an attorney, agent, or other authorized official who resides or maintains a place of business within the United States.

The "Contents of Application" section of the application form serves as a checklist of the contents of the application. The section lists 15 items of information that may be included in an application. The application form along with the cover letter and letters of authorization should be packaged together with the Index and the Summary (items 1 and 2) and bound together in a single volume. Patent information on the applicant's drug (item 13) and any patent certification with respect to the drug (item 14) should be submitted on a separate piece of paper and attached to the application form.

The regulations require that the form identify all investigational new drug applications (IND's), drug master files (DMF's), and other applications that are referenced in the application. To provide this information, FDA recommends that the applicant use the following format:

Type of Document (IND, NDA, DMF)	Title or Document Number	Volume, Subject of Document	Document Holder	Page #'s, Dates, etc.
----------------------------------	--------------------------	-----------------------------	-----------------	-----------------------

The application form (FDA 356h) may be obtained from:

Forms and Publication Distribution
(HFA-268)
12100 Parklawn Drive
Rockville, Maryland 20852

b. Index (§ 314.50(b))

The application is required to contain a comprehensive index by volume and page number to the summary, to the review sections, and to any supporting information. It is recommended that in the less extensive submissions (e.g., most ANDAs, supplements, and amendments), the cover letter, application form, index, and summary (if one is required) all be bound with the chemistry review section. The index should reflect all the elements of an application described in § 314.50(b) through (f). For each element, identify the beginning volume and page number. If microfiche is used for portions of an application, the fiche number should also be given.

c. Summary (§ 314.50(c))

See the "Guideline for the Format and Content of the Summary for New Drug and Antibiotic Applications."

d. Review sections (§ 314.50(d))

Items 4-12 on the Form FM 356h should be submitted in separately bound volumes. As noted above, item 3 may be combined with the first volume if the submission is

small. For more details on the format and content of each review section, refer to the relevant guidelines.

e. Samples and labeling section (§ 314.50(e))

(1) Samples and methods validation Refer to the "Guideline for Submitting Samples and Analytic Data for Methods Validation."

(2) Labeling

Four copies of draft labeling or 12 copies of the final printed labeling (FPL) must be submitted. It is recommended that the labeling be submitted as follows:

When draft labeling is submitted, one copy should be placed in the archival copy. Single copies should also be placed in the chemistry, pharmacology, and clinical review sections of the application. If additional copies are submitted, they should be placed in the other review sections of the application.

When FPL and carton labeling is submitted, one copy should be mounted, bound, and inserted in the archival copy. The remaining 11 copies of FPL should be mounted, bound, and submitted in a separate jacket clearly labeled "Final Printed Labeling."

f. Case report forms and tabulations (§ 314.50(f))

Before submitting an application, applicants are encouraged to meet with FM to discuss the extent to which tabulations of patient data in clinical studies, data elements within tables, and case report forms are needed. Such discussions can also cover alternative modes of data presentation and the need for special supporting information (for example, electrocardiograms, x-rays, or pathology slides.)

(1) Case report tabulations

Tabulations of the data on individual patients are required for:

- (a) The initial clinical pharmacology (phase 1) studies.
- (b) The adequate and well-controlled clinical studies.
- (c) The safety data, e.g., side effects, adverse reactions, and laboratory data from all other studies (that is, Phase 2 or Phase 3 studies that are not considered adequate and well controlled).

Efficacy data on patients from Phase 2 or 3 studies that are not adequate and well-controlled need not be tabulated. Upon request, FDA will discuss with the applicant in a "pre-NDA conference those tabulations that the agency agrees may be deleted because they are not considered pertinent to a review

of the drug's safety and effectiveness. Barring unforeseen circumstances, tabulations agreed to be deleted at such a conference will not be requested during the FDA's review of the application. If such unforeseen circumstances do occur, any request for deleted tabulations will be made by the director of the FDA division responsible for reviewing the application.

(2) Case report form

The routine submission of copies of all case report forms for each clinical study is not required. Instead, unless waived by FDA, case report forms are required for:

- (a) All patients who died during a clinical study.
- (b) Patients who did not complete a study because of any adverse event, whether or not the adverse event is considered drug related by the investigator or sponsor, including patients receiving reference drugs or placebo.

Additional case report forms needed to properly review the application may be requested by the director of the FDA division responsible for reviewing the application. The division director will make every effort to designate the critical studies for which case report forms will be required approximately 30 days after receipt of the application.

The applicant's failure to submit information requested by FDA within 30 days after receipt of the request may result in the agency viewing any eventual submission as a major amendment under § 314.60 and extending the review periods as necessary.

g. Information incorporated by reference (§ 314.50(g))

Applicants may incorporate by reference information that they have previously submitted in drug master files (DMFs) or other applications. An incorporation by reference should be made in that segment of the application where the information referenced would ordinarily appear. The incorporation by reference must identify specifically where the agency can find the information in the LM or other application. The reference is required to identify the file by name, reference number, volume, and page number in the agency's records where the information can be found.

In cases where the applicant is cross-referencing a file submitted by another firm, a letter of authorization containing the information described above is required from the owner of the file. The letter of authorization should be placed behind the Form 356h in the archival copy and each appropriate review copy.

2. Review Copy

Each review section must be separately bound. Each review copy should include a table of contents for the section, a copy of the application form (FDA 356h), a copy of the cover letter, any letter of reference or authorization, a copy of the index to the entire application, and a copy of the application summary. A breakdown of the recommended contents of the review sections is given in Appendix A.

3. Pre-submission of Chemistry, Manufacturing, and Controls Section

An applicant may submit a complete chemistry, manufacturing, and controls section before the submission of the remainder of the application. (See § 314.50(d)(1)(iv).) The pre-submission should be made 90 to 120 days before the anticipated date of submission of the full application. The early submission and review by FDA of this information may speed the review of an application. FDA's ability to review these early submissions will depend upon availability of adequate agency resources.

Both an archival copy (bound in a blue jacket) and a review copy (bound in a red jacket) should be submitted. Each copy should contain a cover letter identifying a person with whom the PDA reviewer may directly discuss the chemistry, manufacturing, and control data, the application form (FDA 356h), and an index to facilitate location of the information within the review section.

The volumes in the pre-submission should be numbered from 1.1. When the rest of the application is subsequently submitted, the volumes should be numbered from 2.1 on. The index for the full application should identify the information in the pre-submission. The chemistry review section in the full submission need not include information submitted in the pre-submission.

If any information required in the chemistry, manufacturing, and control section (21 CFR 314.60(d)) is not available at the time of the pre-submission, the information that is omitted should be noted in the cover letter.

The cover letter, application form, and mailing cover should be plainly marked "Pre-NDA Submission of Chemistry, Manufacturing, and Controls Data." The submission should be directed to:

Food and Drug Administration
Center for Drugs and Biologics
Central Document Room
Park Building, Room 214
12420 Parklawn Drive
Rockville, Maryland 20852

B. Abbreviated Applications (ANDAs)

FDA has developed written guidance on the content and format of abbreviated applications, including abbreviated applications for antibiotic drugs. Questions regarding the content and format of abbreviated applications should be addressed to the Consumer Safety Officer Staff in the Division of Generic Drugs (301-443-0193).

IV. OTHER AVAILABLE GUIDELINES

In addition to this guideline, FDA has developed the following other guidelines to assist applicants in preparing marketing applications for new drugs and antibiotics:

1. Guidelines for the Format and Content of the Summary for New Drug and Antibiotic Applications.
2. Guideline for the Format and Content of the Chemistry, Manufacturing, and Controls Section of an Application.
3. Guideline for the Format and Content of the Nonclinical Pharmacology/Toxicology Section of an Application.
4. Guideline for the Format and Content of the Human Pharmacokinetics and Bioavailability Section of an Application.
5. Guideline for the Format and Content of the Microbiology Section of an Application.
6. Guideline for the Format and Content of the Clinical and Statistical Sections of an Application.
7. Guideline for the Submission in Microfiche of the Archival Copy of an Application.
8. Guideline for Submitting Supporting Documentation in Drug Applications for the Manufacture of Drug Substances.
9. Guideline for Submitting Documentation for the Manufacture of and Controls for Drug Products.
10. Guideline for Submitting Samples and Analytical Data for Methods Validation.
11. Guideline for Submitting Documentation for Packaging for Human Drugs and Biologics.
12. Guideline for Submitting Supporting Documentation for the Stability of Human Drugs and Biologics.

Additional guidelines are available. The Center for Drugs and Biologics maintains a list of guidelines that apply to the Center's regulations. The list states how to obtain a copy of each guideline. A request for a copy of the list should be directed to the Legislative, Professional, and Consumer Affairs Branch (HIM-365), Center for Drugs and Biologics, Food and Drug Administration, 5600 Fishers Lane; Rockville, MD 20857.

APPENDIX A

Contents of Application

Elements of NDA	Archival Sections of the Review Copy						
	Blue	Chemistry Red	Pharma- cology Yellow	Pharma- co- kinetics Orange	Micro- biology White	Clinical Light- Brown	Statistics Green
Application Form (356h)	X	X	X	X	X	X	X
• cover letter	X	X	X	X	X	X	X
• patent information	X	X	X	X	X	X	X
• letter of authorization (if applicable)	X	X	X	X	X	X	X
1. Index to application	X	X	X	X	X	X	X
• index to section ^a	--	X	X	X	X	X	X
2. Summary	X	X	X	X	X	X	X
3. Chemistry Manufacturing Controls	X	X	--	--	--	--	--
4. Samples ^b	--	--	--	--	--	--	--
• Methods Validation ^c	X	X	--	--	--	--	--
• Labeling ^d							
– draft labeling (4 copies) or	X	X	X	--	--	X	--
– FPL (12 copies)	X	--	--	--	--	--	--
5. Nonclinical Pharmacology Toxicology	X	--	X	--	--	--	--
6. Human Pharmokinetics Bioavailability	X	--	--	X	--	--	--
7. Microbiology (if required)	X	--	--	--	X	--	--
8. Clinical Data	X	--	--	--	--	X	--

Elements of NDA	Archival Sections of the Review Copy						
	Blue	Chemistry Red	Pharma- cology Yellow	Pharma co- kinetics Orange	Micro- biology White	Clinical Light- Brown	Statistics Green
9. Safety Update	X	--	--	--	--	X	--
10. Statistical Data	X	--	--	--	--	--	X
11. Case Report Tabulations	X	--	--	--	--	--	--
12. Case report Forms	X	--	--	--	--	--	--
13. Patent Information	Attached to application form	X	X	X	X	X	X
14. Patent Certification	X	X	X	X	X	X	X
15. Other (if applicable)	X	X	X	X	X	X	X

- a Review Sections should contain a copy of the index to the entire application in addition to the index for the specific section.
- b Samples should be submitted upon request.
- c One copy of methods validation should be submitted in the archival copy; three copies should be submitted in the chemistry section of the review copy.
- d The applicant should submit 4 copies of draft labeling or 12 copies of FPL (if available). The archival copy should contain 1 copy of all proposed labeling for the product (draft labeling or FPL and carton labeling, if available).

APPENDIX B-1

Addresses for Submissions to FDA

Type of Submission

- o Original full application for new drug or antibiotic (§ 314.50)
- o Original DMF, amendments to DMF, and all correspondence relating to DMF

Address

Food and Drug Administration
Center for Drugs and Biologics
Central Document Room
Park Building, Room 214
12420 Parklawn Drive
Rockville, Maryland 20852

o 15-day Alert Report or periodic adverse drug experience report (for all full and abbreviated applications) (§ 314.30)

- o Original IND

The following submissions relating to a full application under §314.50:

- o Annual reports (§ 314.81(b))
- o Amendments (§ 314.50)
- o Safety update (§ 314.50(d)(5))
- o All correspondence relating to application

Sued to FM division responsible for review of the application. The review divisions and their addresses are listed in Appendix 8-2, (vi)(b)) below.

The following submissions relating to an IND:

- o All amendments
- o All safety reports and other required reports
- o All correspondence

Send to FLEA division responsible for review of the application. (See Appendix 8-2, below.)

The following submissions relating to an abbreviated application for a new drug:

- o original application (§ 314.55)
- o Annual report
- o All correspondence relating to application
- o Amendments

Food and Drug Administration
Center for Drugs and Biologics
Division of Generic Drugs
HM-230) Room 16-72
5600 Fishers Lane
Rockville, Maryland 20857

The following submissions relating to an abbreviated application for an antibiotic:

- o Original application (§ 314.55)
- o Annual report
- o Amendments
- o All correspondence relating to application

Food and Drug Administration
Center for Drugs and Biologics
Division of Generic Drugs
Antibiotic Review Branch
(HILT-235) Roam 17-4f3
5600 Fishers lane
Rockville, Maryland 20057

- o IND's for biological products
- o Applications and other correspondence for products listed in § 314.440(b)

Food and Drug Administration
Center for Dugs and Biologics
Office of Biologics Research and Review (HFN-325)
3800 Rockville Pike
Bethesda, Maryland 20205

APPENDIX B-2

Addresses for FM Review Divisions

Division of Cardio-Renal Drug Products
Center for Drugs and Biologics (HM-310)
Document Control Room 16B30
5600 Fishers Lane
Rockville, Maryland 20857

Division of Neuropharmacological Drug Products
Center for Drugs and Biologics (HFM-120)
Document Control Room 10830
5600 Fishers Lane
Rockville, Maryland 20857

Division of Metabolism and Endocrine Drug Products
Center for Drugs and Biologics (HFN-810)
Document Control Room 14803
5600 Fishers Lane
Rockville, Maryland 20857

Division of Anti-Infective Drug Products
Center for Drugs and Biologics (HFN-815)
Document Control Room 12830
5600 Fishers Lane
Rockville, Maryland 20857

Division of Oncology and Radiopharmaceutical Drug Products
Center for Drugs and Biologics (HFN-150)
Document Control Room 9823
5600 Fishers Lane
Rockville, Maryland 0857

Division of Surgical-Dental Drug Products
Center for Drugs and Biologics (HM-160)
Document Control Room 18803
5600 Fishers Lane
Rockville, Maryland 20857